

Mobile **Hwy** Ads

LABELS • LABELING SYSTEMS • DECALS

Phone: (707)492-5678 info@MobileHwyAds.com

www.MobileHwyAds.com

Electronic File Guidelines

Please follow these guidelines when preparing electronic files for submission. Taking proper care in the creation and submission of artwork will avoid time consuming and costly revisions. If you have specific questions which aren't addressed here, please contact customer service or the prepress department.

File Preparation

Software Supported

- Adobe Illustrator
- Adobe InDesign
- Adobe Photoshop
- Macromedia Freehand

In general, illustration applications (Illustrator, Freehand) are preferable for label artwork preparation. Page layout applications such as QuarkXPress are accepted, but artists are advised to use care in defining colors, layout size, and special situations such as overprints, knockouts, and spot colors. Hard copy printouts should accompany all file submissions.

Files may also be submitted in PC-Windows format from the above applications, but note the following guidelines:

- Save the file as an EPS
- Include a list of fonts used
- Convert all non-standard fonts to paths/curves

Because of cross-platform font and application issues, it is essential that a hard copy printout of the document be submitted.

Files From Other Applications:

Files from Microsoft Publisher, PowerPoint, or Microsoft Word are generally not suitable for digital prepress. These applications generally lack the ability to accurately define label size, colors used and do not provide proper font management.

Files submitted from these applications may require an additional artwork expense to recreate the art in a proper illustration program.

Media Accepted:

Files may be submitted on the following types of media:

CD ROM (Macintosh or Windows)

or emailed to your customer service representative. Large electronic files can also be uploaded to our server at:

<https://office.tfggraphics.com:7001>

Username: uploads

Password: tlfuploads To upload your file -

Open the "General" folder.

Open Mobile_Hwy_Advertising folder.

Click the upload button on the top left.

Then choose upload - skip from the options.

Then pick your file and click Open

File Compression:

It is recommended that all files submitted electronically be compressed, this will maximize file transfer speed and prevent corruption. Use Stuffit (Macintosh) or any Windows Zip utility to save files as .sit or .zip files

Art Requirements

File Setup:

All orders should be accompanied by hard copy, showing color and dimensions. A PDF or jpeg may be substituted in place of laser or inkjet print.

Please name your file in a way which corresponds to your job such as a part number or item number or company name.

We have a large library of fonts, but if you use any special fonts please include both the printer and Screen fonts. Avoid using true type fonts. To avoid font related issues it is helpful to convert the font to paths or outlines when using illustrator, Freehand, or InDesign.

Images pulled from the web are seldom usable for print production. Vector files created in drawing programs like Illustrator and Freehand result in far better quality than file saved as raster format such as Gif, Jpeg, Tiff and BMP. Raster files should be at least 300 DPI at finished size.

Be sure to include all placed images and logos.

Color samples for any special color match should be included. Please provide Pantone color reference number whenever possible.

All artwork which extends to the edge of the label should bleed .0625" minimum. All elements which do not bleed should maintain a .0625 distance from the trim.

For specific questions which aren't addressed here, please contact customer service or the prepress department

Left Art

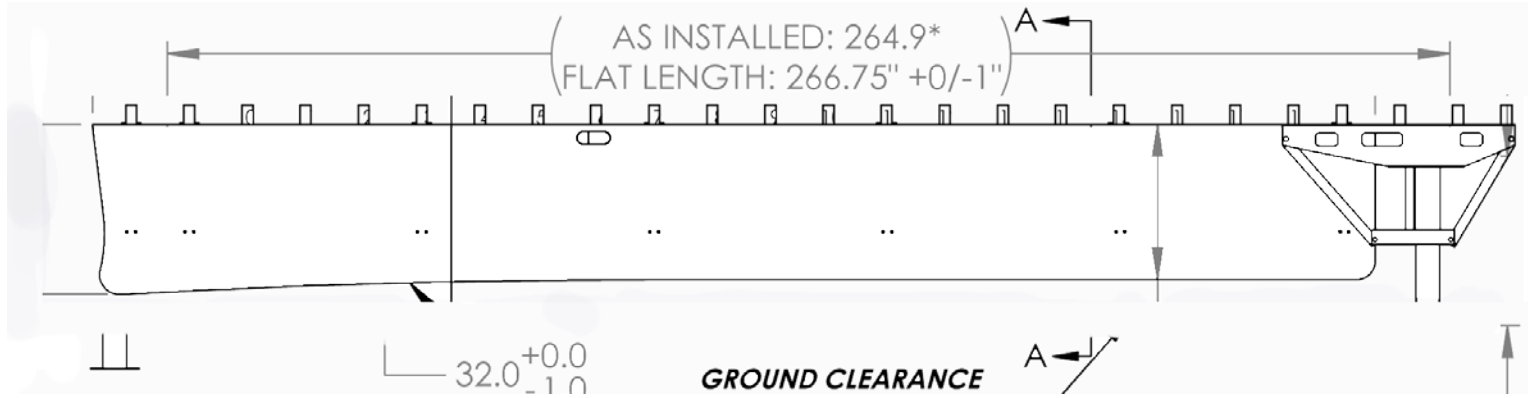

Right Art

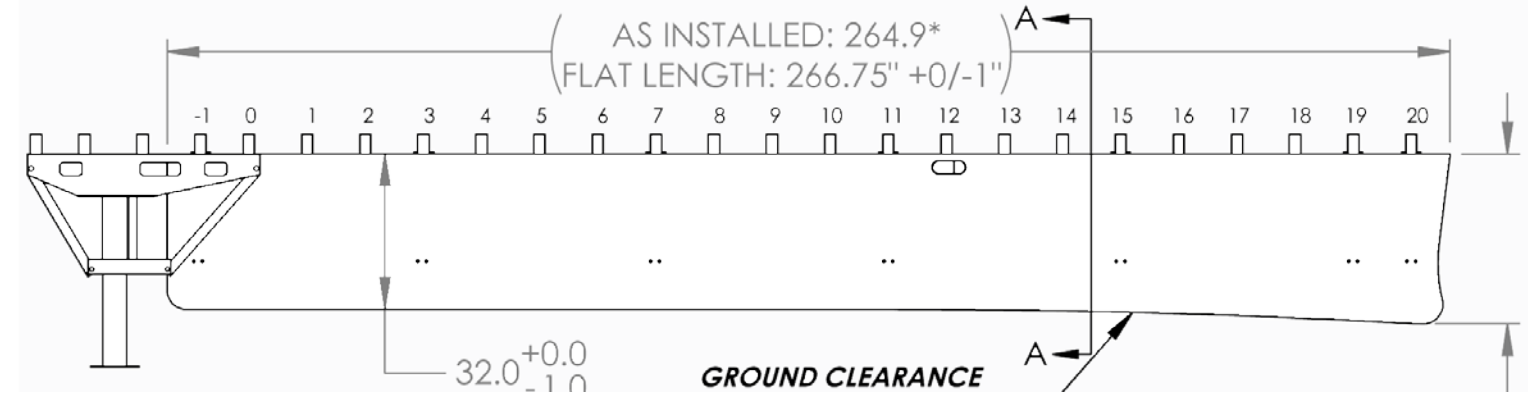

Example of finished art

